

## Tubular Bells, Ground Fix 23163

manufacturer instructions are included with the product when purchased – these are simply a summary



### Contents

Pre-assembled Tubular Bells  
 1 pair of Large Red Beaters  
 Ground fix components:

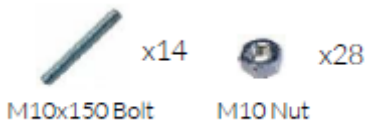

### Before Installation

Choose a suitable location for the Tubular Bells, bearing in mind the amount of space required around the chimes and the depth required: allow 600mm for each chime and 400mm for beater poles:

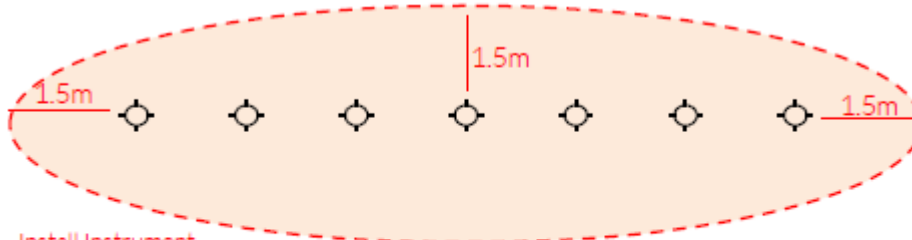

Install Instrument  
 with 1.5m free space  
 (from widest point)  
 around it.

Bear in mind the product weight:

Weight of heaviest part: 10kg (XXL Bell)

Total weight: 59g

### Installation

1. Using M10 nuts and 150mm bolts supplied locate through pre drilled holes and secure bolts in place to support in ground pole in concrete. 2 bolts per leg at 90 degree angles

2. Excavate 7 holes for Tubular Bells 250mm diameter by 600mm deep. 2 further holes will be needed for the beater poles according to layout of Bells at 250mm diameter and 400mm deep.

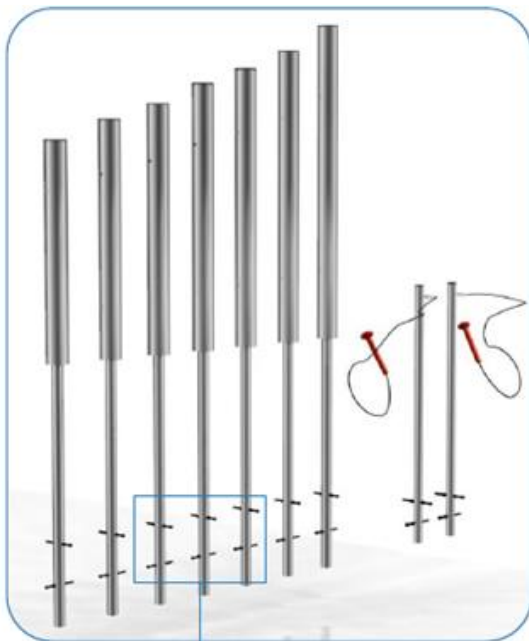

3. Locate (lower) legs into holes making sure they are vertical and level prior to concreting in place



4. Once happy with location of the Tubular Bells, fill holes using rapid hardening concrete. Be sure to compact concrete around legs and leave to dry according to manufactures guidelines

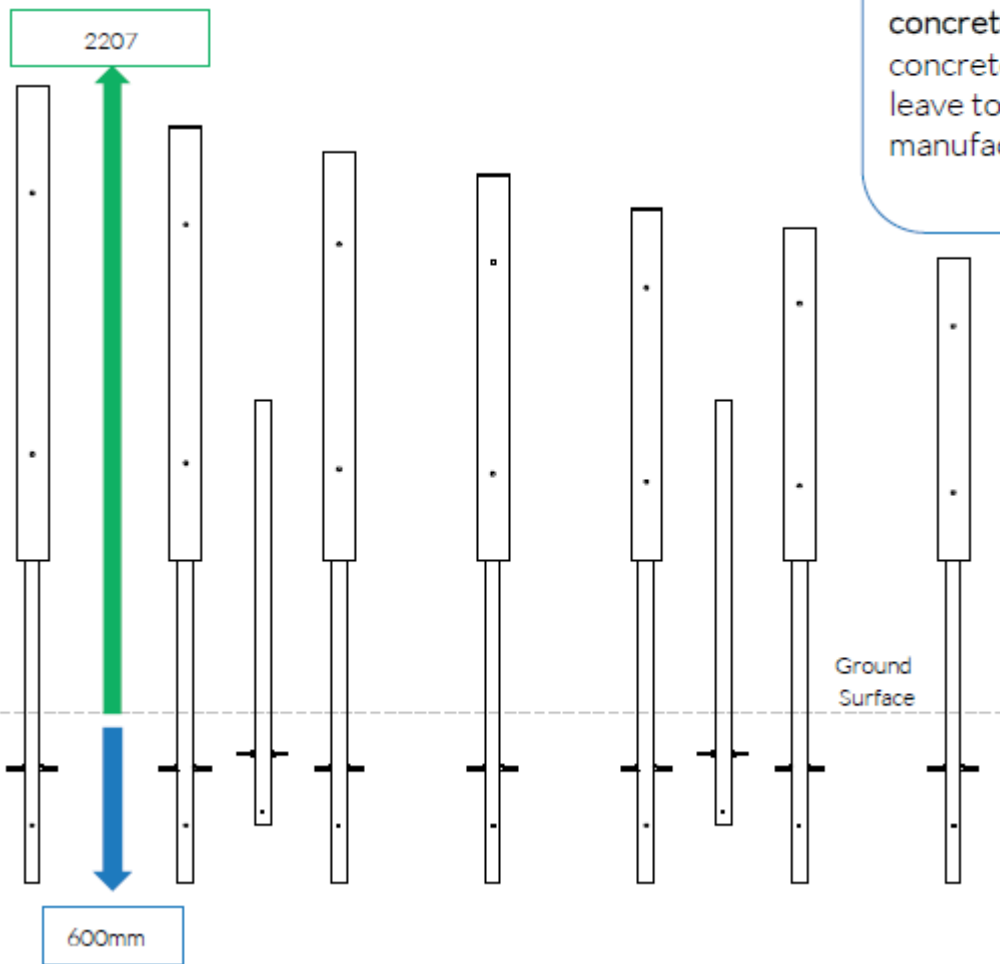

## Ground Fix Installation

Foundations should not present a hazard. these foundations are recommended as a guide, for more information on foundation details for various surfaces see Part 7 of BS EN 1176

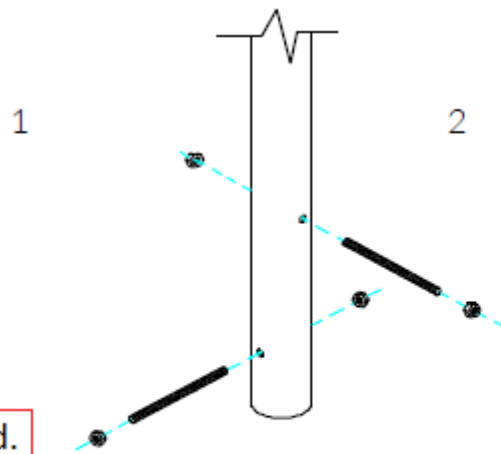

1  
Insert M10x 150 Threaded bar into pre drilled holes in Ground Fixing Post



2  
Fix M10x 150 Threaded bar in place using M10 Nuts

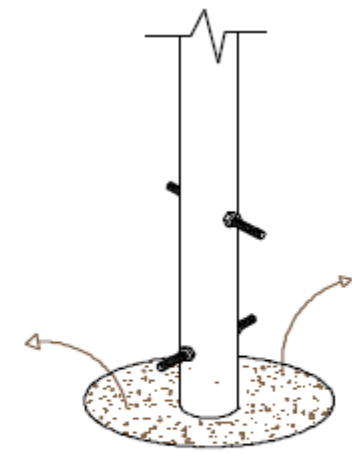

3  
Excavate 7 holes with a 250mm diameter tapering down to 350mm diameter and 650mm depth

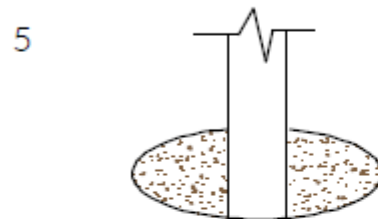

5  
Compact base of hole with 50mm of aggregate. Lower ground Fix post attached to instrument into hole (check instrument straight and level before filling with concrete)

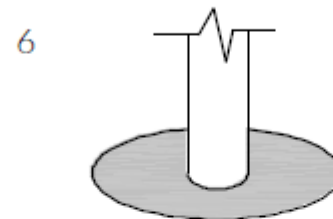

6  
Fix hole with fast drying concrete to manufacturers specifications.

600mm max depth 7x Tubular Bells  
400mm max depth 2X Beater Poles

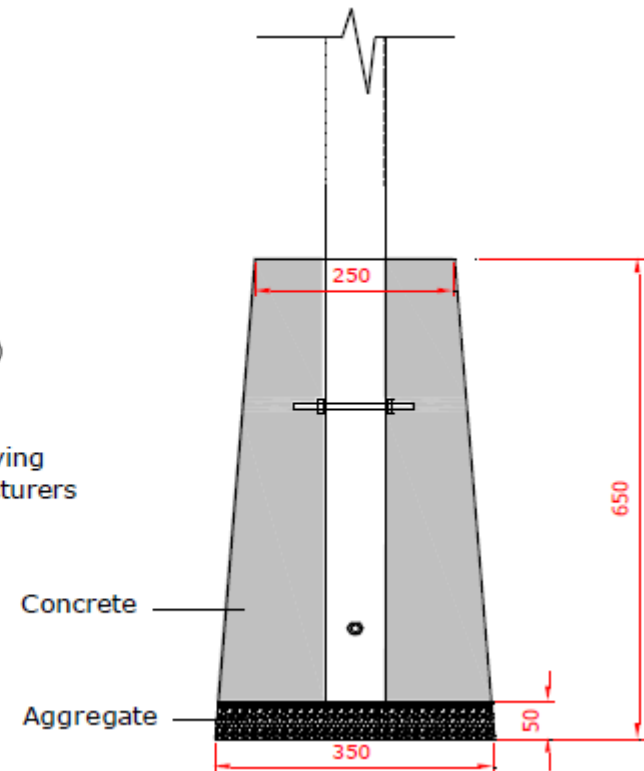

## Care & Maintenance

- Establish a schedule for regularly checking your outdoor musical instruments. Regularly inspect them and maintain them accordingly.
- Failure to adequately care for and maintain your products can affect the warranty.
- Do not alter or modify the product in such a way that the essential safety or sound of the product will be affected. Alterations and modifications may affect the warranty.
- Contact ROMPA® should spare parts or additional beaters be required. Contact ROMPA® should any repair or replacement be necessary.

## Aluminium Notes

Aluminium notes have an anodic coating that can't be peeled off or flake away.

Keep the notes clean with soapy water or a mild detergent solution followed by rinsing with clean cold water.

After drying, a good household wax spray polish can be used.

Grease and dirt deposits may be removed by using solvents such as white spirit in conjunction with a soft cloth or soft bristle brush.

Never use harsh abrasives to clean the notes.

As the notes are permanently exposed to some atmospheric weathering, they should be regularly cleaned – not less than four times a year.

## Steel Leg

Keep clean to ensure longevity.

Wipe clean with a mild detergent and rinse with clean cold water.

All cleaning solutions including acide based (exceptic hydrochloric acid) are suitable, as long as thoroughly rinsed with clean water afterwards.

Stainless steel polish can be used should you wish to cover any blemishes which may be caused over the years, either by misuse or accidental damage.

Stainless steel is very low maintenance but in external areas it is recommended to be checked for blemishes or surface scratches.

## Metal Posts installed below ground level

Check posts to see whether particular conditions (e.g. salt water, electrolytic corrosion) have caused pitting or a waekening of the installed post at ground level. Below is a test procedure that allows you to inspect the posts installed:

Remove surfacing surrounding the post at foundation level to check for anomalies or damage from vandalism. If posts weaken or are subject to vandalism, the instable post has to be repaired by an expert, or be replaced. Contact ROMPA®.

## EN1176 Requirements (applies to Children's Playground Equipment)

All children's playground equipment is subject to regular inspections and maintenance works.

Maintain your outdoor musical instruments according to the instructions supplied with the product to look after the product and to adhere to the warranty requirements.

*Excerpt from EN 1176-7:*

Section 7 - Inspection schedule

7.1. To avoid accidents, the operator has to make sure that an adequate inspection schedule is developed and adhered to for each playground. In such a schedule, all local conditions and manufacturer's indications that may have an influence on the necessary maintenance frequency, have to be taken into consideration.

The inspection schedule should list all parts, which have to be checked during the different inspections, and the inspection procedures.

7.2. If severe and safety-endangering defects are discovered during an inspection, they should be eliminated immediately. If they cannot be repaired or replaced at once, the respective equipment has to be excluded from use, e.g. by dismantling or closing it down. If an equipment component has to be removed, e.g. for maintenance works, all anchoring or foundations that remain in the ground have to be removed also or be made inaccessible by means of covers. The construction site should then be secured.

As stated in the standards, we recommend a weekly 'Routine Visual Inspection' of your playground. In cases of heavily used or high-risk (e.g. vandalism) playgrounds or if the age of the equipment requires more frequent checks, you may want to increase the frequency of these inspections to daily. An 'Operational Inspection' should be carried out every month and after 12 months at the latest you are required to carry out an 'Annual Inspection' (for best effect this should be completed after the winter months).

Records should be kept alongside these instructions of all actions taken as part of safety management. On the last pages of these maintenance instructions you are offered a Maintenance Record Sheet for the entry of your maintenance report results.

### **Daily/Weekly Visual Routine Inspection**

The routine maintenance of your outdoor musical instruments consists of preventative measures to maintain their level of safety and performance. On a 'Daily/Weekly Visual Routine Inspection' check for visible damage and loose parts:

- Are there any exposed foundations?
- Can you see sharp edges, broken, frayed or missing parts?
- Are components overly worn and torn?

Daily inspection is recommended for heavily-used or high-vandal-risk playgrounds or those that have already been in service for a certain period of time. Deal with all damages and defects as soon as these are found. Record all findings in the Maintenance Record Sheet (below).

### **Monthly Operational Inspection**

As for the Weekly Visual Routine Inspection, the following checks have to be carried out during the Monthly Operational Inspection:

- Are there any exposed foundations?
- Can you see sharp edges, broken, frayed or missing parts?
- Are components overly worn and torn?

The 'Monthly Operational Inspection' requires the following supplementary checks:

- Are all metal parts well connected and not worn down?
- Are all screwed connections and bolted joints tight? If not, please tighten them.
- Are all plastic and or/rubber components satisfactory?

Deal with all damages and defects as soon as these are found. Record all findings in the Maintenance Record Sheet (below).

### **Annual Inspection**

Carry out the 'Annual Inspection' after the winter or at least after 12 months. As well as the checks described above (Daily, Weekly, Monthly), the following checks are required:

- Are all foundations stable and the equipment well anchored?
- Replace joints that show severe corrosions or heavy wear and tear

Deal with all damages and defects as soon as these are found. Record all findings in the Maintenance Record Sheet (below). Copy the sheet or create your own for ongoing maintenance reporting.

Date of Inspection	Inspection (Daily/ Weekly/ Monthly /Annual)	Name of Inspector	Name of Instrument Inspected	Details of Defect Found	Action Taken	Date Defect Resolved